

ENGINE COMPONENT INSPECTION AND SERVICE

CYLINDER - PISTON TABLE

Part	Value (mm)
	50cc
Cylinder	Ø 39
Piston	Ø 39
Piston rings :	_____
1)Piston ring 1st slot	Ø 39 x 2 - 0.01 - 0.025
2)Piston ring 2nd slot	Ø 39 x 1.25 - 0.01 - 0.025

**CYLINDER - PISTON
ASSEMBLY SELECTION TABLE**

SIZE CODE (stamped on part)	CYLINDER - PISTON DIMENSIONS mm		ASSEMBLY CLEARANCE
	CYLINDER	PISTON	
A	$\varnothing 39 \begin{smallmatrix} +0,010 \\ +0,005 \end{smallmatrix}$	$\varnothing 39 \begin{smallmatrix} -0,025 \\ -0,030 \end{smallmatrix}$	0.030 - 0.040 mm
B	$\varnothing 39 \begin{smallmatrix} +0,015 \\ +0,010 \end{smallmatrix}$	$\varnothing 39 \begin{smallmatrix} -0,020 \\ -0,025 \end{smallmatrix}$	
C	$\varnothing 39 \begin{smallmatrix} +0,020 \\ +0,015 \end{smallmatrix}$	$\varnothing 39 \begin{smallmatrix} -0,015 \\ -0,020 \end{smallmatrix}$	
D	$\varnothing 39 \begin{smallmatrix} +0,025 \\ +0,020 \end{smallmatrix}$	$\varnothing 39 \begin{smallmatrix} -0,010 \\ -0,015 \end{smallmatrix}$	
E	$\varnothing 39 \begin{smallmatrix} +0,030 \\ +0,025 \end{smallmatrix}$	$\varnothing 39 \begin{smallmatrix} -0,005 \\ -0,010 \end{smallmatrix}$	
F	$\varnothing 39 \begin{smallmatrix} +0,035 \\ +0,030 \end{smallmatrix}$	$\varnothing 39 \begin{smallmatrix} -0 \\ -0,005 \end{smallmatrix}$	

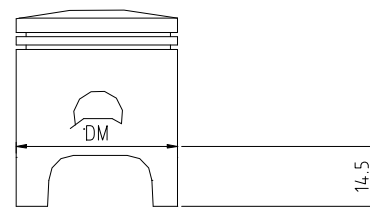
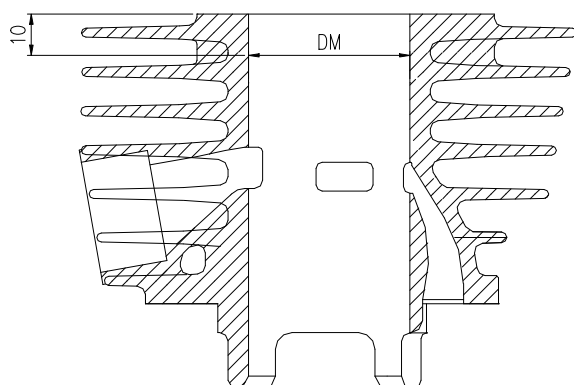
**CHECK POSITION
For correct dimension control**

CYLINDER CHECK

- Check the internal surface of the cylinder for signs of seizure or abnormal wear.
- Measure the internal diameter of the cylinder using a bore gauge.
- Wear limit: Minimum indicated cylinder selection diameter + 0.03mm.**
- Take measurements in three different positions along the axis of the cylinder.
- In each position take two measurements, one parallel with and the other perpendicular to the crankshaft axis.

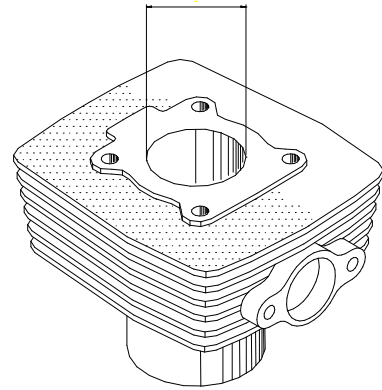

PISTON CHECK

- Remove the piston rings and check the piston for abnormal signs and wear.

N.B.

The piston rings are fragile, handle with care.



RING-TO-GROOVE MEASUREMENT.

Wear limit: 0,08 mm max.

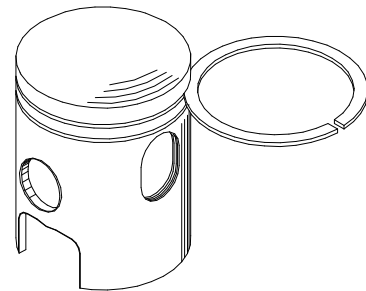

PISTON BORE MEASUREMENT.

- Maximum permitted diameter: $12 + 0,18$ mm
- Measure the piston outside diameter in the direction perpendicular to the piston axis at **14,5 mm** from the skirt.

